

# Kelly KVD Trapezoidal Brushless Motor Controller User's Manual

## Devices Supported:

KVD2412N	KVD2415N	KVD2418N
KVD2430N	KVD2445N	KVD2412NX
KVD7212N	KVD7215N	KVD7218N
KVD7212NX	KVD6018N	KVD6030N
KVD7230N	KVD7245N	KVD7250N

Rev.1.12  
DEC.2020



# Contents

- Chapter 1 Introduction..... 3
  - 1.1 Overview..... 3
- Chapter 2 Features and Specifications..... 4
  - 2.1 General functions..... 4
  - 2.2 Features..... 5
  - 2.3 Specifications..... 6
  - 2.4 Name Regulation..... 6
- Chapter 3 Wiring and Installation..... 7
  - 3.1 Mounting the Controller..... 7
  - 3.2 Connections..... 12
  - 3.3 Installation Check List..... 18
- Chapter 4 Programmable Parameters..... 19
  - 4.1 Vehicle Setting ..... 20
  - 4.2 Motor Setting..... 28
  - 4.3 Control Setting..... 30
  - 4.4 Monitor Screen..... 32
  - 4.5 Simple Wiring Diagram for Auto Identify Function..... 33
- Chapter 5 Maintenance..... 35
  - 5.1 Cleaning..... 35
  - 5.2 Configuration..... 36
- Table 1: ERROR CODES..... 37
- Contact Us:..... 39

# Chapter 1 Introduction

## 1.1 Overview

This manual introduces the Kelly trapezoidal wave brushless BLDC motor controllers' features, their installation and their maintenance. Read the manual carefully and thoroughly before using the controller. If you have any questions, please contact the support center of Kelly Controls.

Kelly's programmable motor controllers provide efficient, smooth and quiet controls for electric motorcycles, golf carts and go-carts, as well as industrial motor control. The KVD motor controller must be based on hall sensors type. KVD controller can not support sensorless brushless motor for now. It uses high power MOSFET's and, PWM to achieve efficiencies of up to 99% in most cases. A powerful microprocessor brings in comprehensive and precise control to the controllers. It also allows users to adjust parameters, conduct tests, and obtain diagnostic information quickly and easily. People can program the KVD controller on PC software and Android App. There is one more choice for customers to program trapezoidal wave controller now. The APP software is based on Tablet with Android OS. Customers may add a Z-TEK USB to RS232 cable for programming KVD controller if they want to use Android Tablet.

Both PC software and Android APP can provide one screen to monitor the controller parameters. Sometimes people can use a small Android Tablet as display device. Customers can connect the KVD controller to Android App in Android Phone if they order Bluetooth converter from Kelly Controls.

KVD has a friendly I/O terminals for customers to hook up the batteries and motor easily.

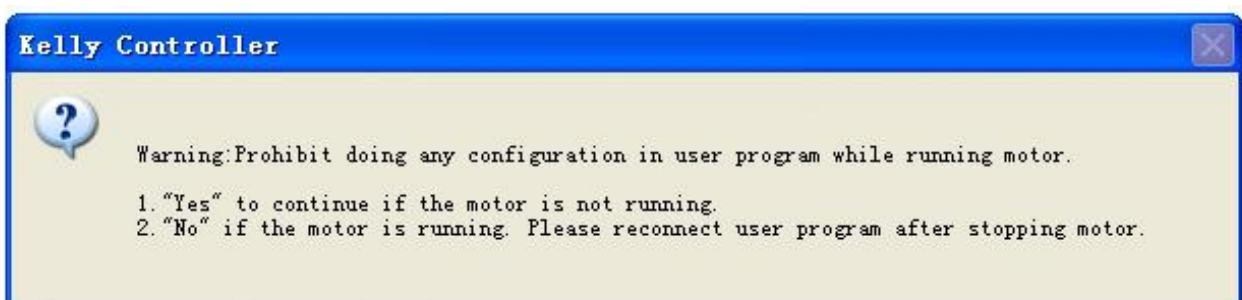

## Chapter 2 Features and Specifications

### 2.1 General functions

- (1) Extended fault detection and protection. Customers can read the error message in PC software or Android APP also.
- (2) Monitoring battery voltage. It will stop driving if the battery voltage is too high and it will progressively cut back motor drive power as battery voltage drops until it cuts out altogether at the preset “Low Battery Voltage” setting.
- (3) Built-in current loop and over current protection.
- (4) Configurable motor temperature protection range.
- (5) Current cutback at low temperature and high temperature to protect battery and controller. The current begins to ramp down at 90°C case temperature, shutting down at 100°C.
- (6) The controller keeps monitoring battery recharging voltage during regen braking.
- (7) Maximum reverse speed and forward speed can be configured between 20% and 100% respectively and separately.
- (8) A 4pin connector to RS232 port and a Z-TEK USB to RS232 cable allows for configuration, programming and software upgrades using the tablet which must be based on Android OS now. People can do the same things on PC software by using a standard USB to RS232 cable instead.
- (9) Provision of a +5 volt and +12 volt output to supply various kinds of hall sensors.
- (10) 5 switch inputs which are activated by connection to 12V. Default to throttle switch, brake switch, reversing switch, forward switch and Boost switch.
- (11) 3 analog 0-5V inputs that default to throttle input, Brake analog input and motor temperature input
- (12) Copy signal of one of hall sensors.
- (13) Configurable boost switch. Enables the maximum output power achievable if the switch is turned on. The effect is the same as full throttle position even if you don't turn throttle at all.
- (14) 12V brake switch input used different port from motor temperature sensor. You can use both brake switch and motor temperature sensor functions at the same time on the latest version. Pin 25 is 12V brake switch input port. Pin1 is motor temperature sensor input port.
- (15) Optional joystick throttle. A bi-symmetrical 0-5V signal for both forward and reversing.
- (16) Configurable motor over-temperature detection and protection with the recommended thermistor KTY84-130/150 or KTY83-122.
- (17) 3 hall position sensor inputs. Open collector, pull up provided.
- (18) Brake analog regen mode. This regen mode doesn't need brake switch to support any more.
- (19) Enhanced regen brake function. A novel ABS technique provides powerful and smooth regen. The regen can happen at any speeds until zero speed.
- (21) Cruise control. If you hold the throttle at certain position above 5-6s, the controller will get into Cruise control.
- (23) Bluetooth function. Required a small Bluetooth converter which needs to be purchased in addition from our website. This small converter is useful for KVD controller also.
- (24) Can support three speed function on the latest version.

**Caution!** *The regen is not a safe function. Usually you may use the mechanical brake.*

## 2.2 Features

- 1) Intelligence with powerful microprocessor.
- 2) Synchronous rectification, ultra low drop, fast PWM to achieve very high efficiency.
- 3) Electronic reversing.
- 4) Voltage monitoring on 3 motor phases, bus, and power supply.
- 5) Voltage monitoring on voltage source 12V and 5V.
- 6) Current sense on all 3 motor phases.
- 7) Current control loop.
- 8) Hardware over current protection.
- 9) Hardware over voltage protection.
- 10) Configurable limit for motor current and battery current.
- 11) Low EMC.
- 12) Battery protection: current cutback, warning and shutdown at configurable high and low battery voltage.
- 13) Rugged aluminum housing for maximum heat dissipation and harsh environment.
- 14) Rugged high current terminals, and rugged aviation connectors for small signal.
- 15) Thermal protection: current cut back, warning and shutdown on high temperature.
- 16) Controller can do Auto\_Identify for different degrees of hall sensors.
- 17) Configurable high pedal protection: the controller will not work if high throttle is detected at power on.
- 18) Current multiplication: Take less current from battery, output more current to motor.
- 19) Easy installation: 3-wire potentiometer will work.
- 20) Standard PC/Laptop computer to do programming. There is one more choice for customers to program KVD controller. Standard Tablet with Android OS to do programming. Need a Z-TEK USB TO RS232 cable for connecting the controller to App program in Tablet.
- 21) User program provided. Easy to use. No cost to customers.
- 22) Support motors with any number of poles.
- 23) Up to 40,000 electric RPM standard. (Electric RPM = mechanical RPM \* motor pole pairs; Motor pole pairs = Motor poles / 2).
- 24) KVD-N: Dust and water protected under sealed condition, IP66

## 2.3 Specifications

- Frequency of Operation: 16.6KHz.
- Standby Battery Current: < 0.5mA.
- 5V or 12V Sensor Supply Current: 40mA.
- Controller supply voltage range: PWR, 40V to 72V for controllers rated equal or lower than 72V. So All KVD-N controllers are non isolated type. KVD24V model: PWR, 20V to 30V
- Supply Current, PWR, 30mA Typical.
- Configurable battery voltage range, B+. Max operating range: 40V to 1.25\*Nominal Voltage. KVD24V model: PWR, 20V to 30V
- Standard Throttle Input: 0-5 Volts(3-wire resistive pot), 1-4 Volts(hall active throttle).
- Throttle Input: 0-5 Volts. Can use 3-wire pot to produce 0-5V signal.
- Full Power Operating Temperature Range: 0°C to 70°C(MOSFET temperature).
- Operating Temperature Range: -40°C to 100°C (MOSFET temperature).
- Max Battery Current :Configurable.

## 2.4 Name Regulation

The name regulation of Kelly BLDC motor controllers:

### KVD 72 12N

**KVD:**Kelly BLDC motor controller based on trapezoidal waveform which is supposed to work with BLDC motor with three hall sensors. All KVD controllers can do regen brake function by default.

**72:**72V batteries.

**N:**The motor controller included a plastic cover with a fuse. There is no fuse or shunt on KVD-N controller at the same time.

And KVD-N is IP66 rating without filling the silica gel by default.

Kelly KVD-N Brushless Motor Controller			
Model	30 seconds Current(Amp)	Continuous Current(Amp)	Voltage(Volt)
KVD2412N	140	60	20<Volt<30
KVD2415N	160	70	20<Volt<30
KVD2418N	220	80	20<Volt<30
KVD2430N	270	90	20<Volt<30
KVD2445N	350	100	20<Volt<30
KVD2412NX	200	75	20<Volt<30
KVD7212N	140	60	40<Volt<90
KVD7215N	160	70	40<Volt<90
KVD7218N	220	80	40<Volt<90
KVD6018N	220	80	40<Volt<80
KVD7212NX	200	75	40<Volt<90
KVD6030N	270	90	40<Volt<80

KVD7230N	270	90	40<Volt<90
KVD7245N	350	100	40<Volt<90
KVD7250N	380	110	40<Volt<90
24V model: range of the batteries voltage is <b>20V-30V</b> . 60V model: range of the batteries voltage is <b>40V-80V</b> . 72V model: range of the batteries voltage is <b>40V-90V</b> .			

## Chapter 3 Wiring and Installation

### 3.1 Mounting the Controller

The controller can be oriented in any position which should be as clean and dry as possible, and if necessary, shielded with a cover to protect it from water and contaminants.

To ensure full rated output power, the controller should be fastened to a clean, flat metal surface with four screws. Applying silicon grease or some other thermal conductive material to contact surface will enhance thermal performance.

Proper heat sinking and airflow are vital to achieve the full power capability of the controller. The case outline and mounting holes' dimensions are shown in Figure 1-6.

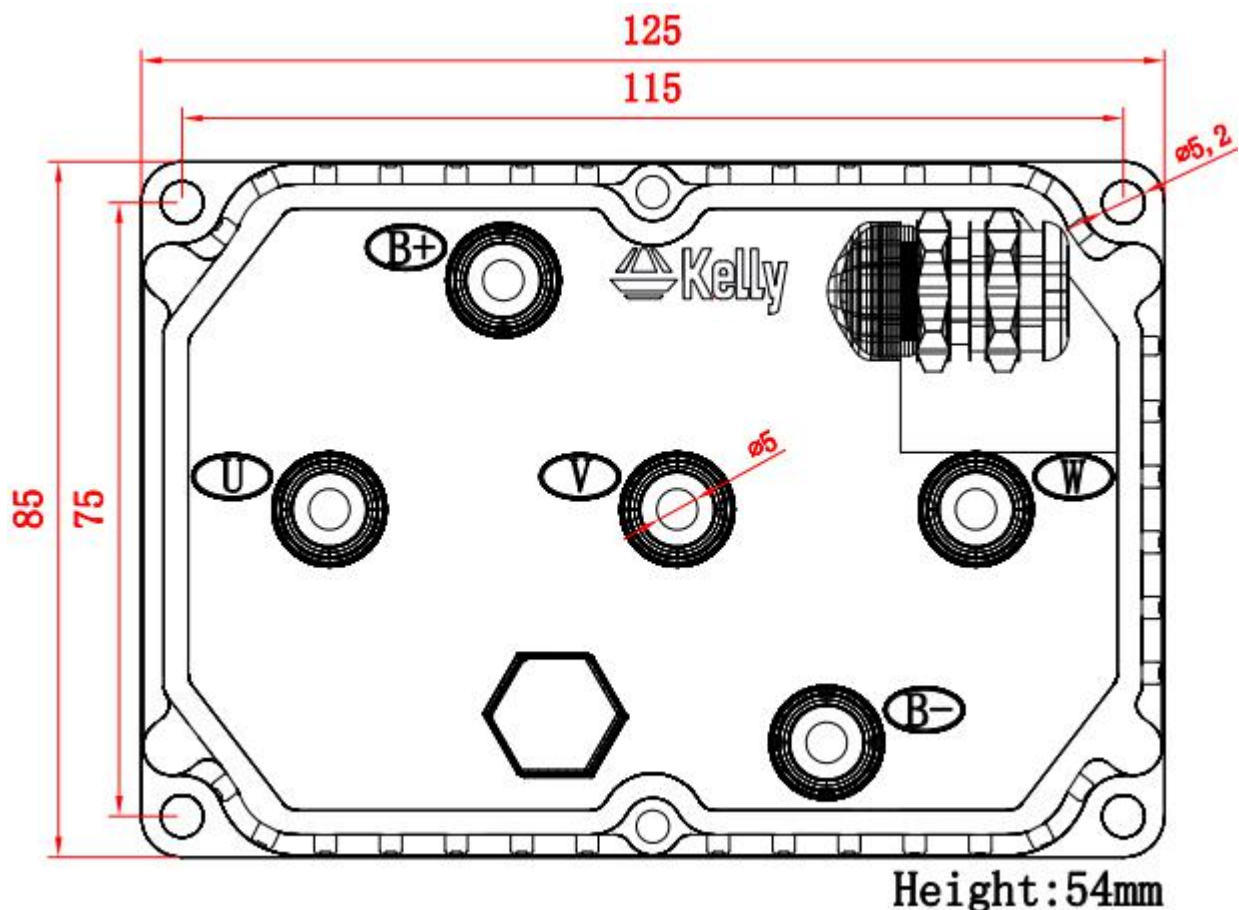
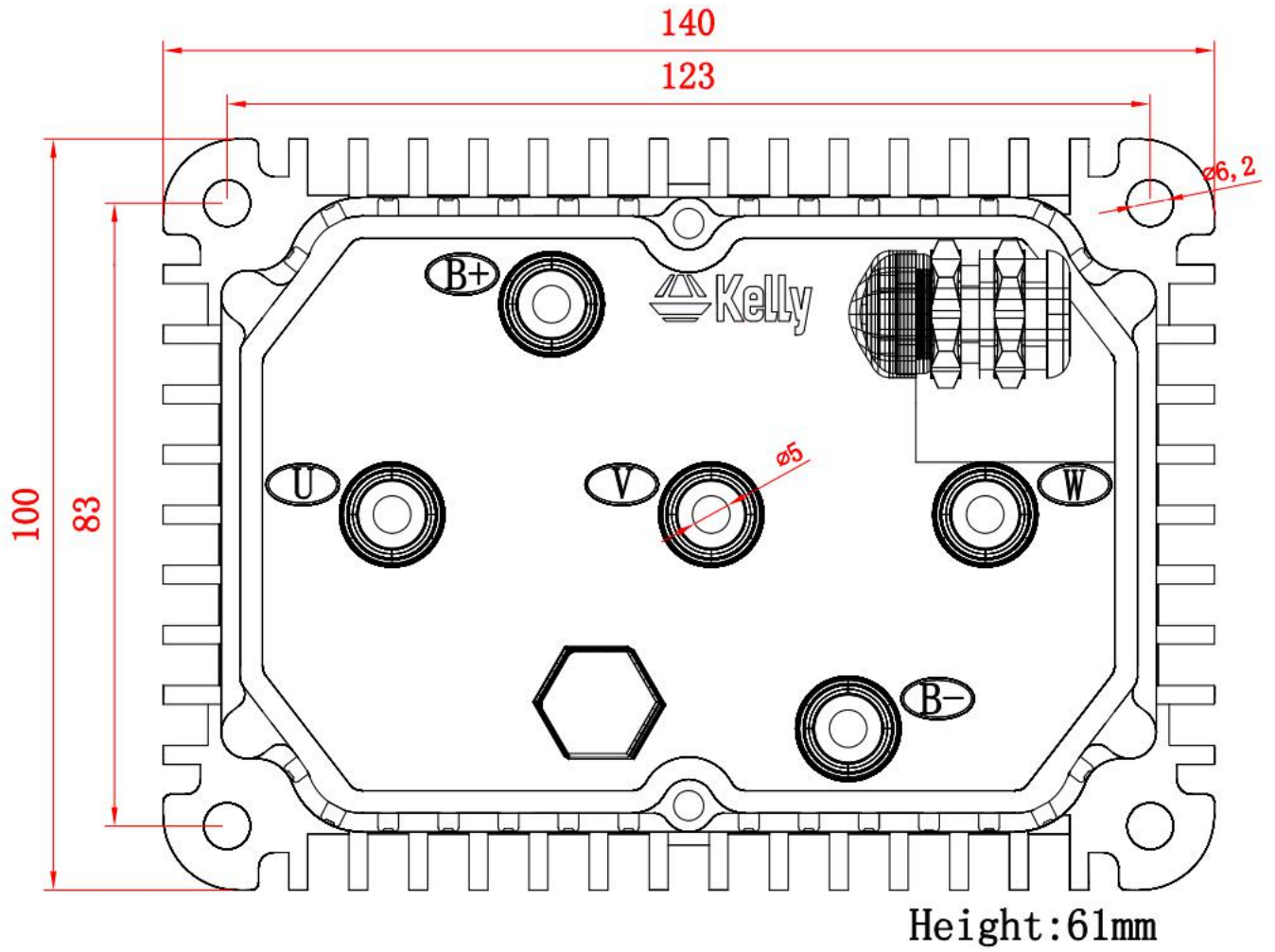

Figure 1: KVD2412N/NX KVD7212N/NX mounting holes' dimensions (dimensions in millimeters)



**Figure 2: KVD2415N, KVD7215N mounting holes' dimensions**  
(dimensions in millimeters)



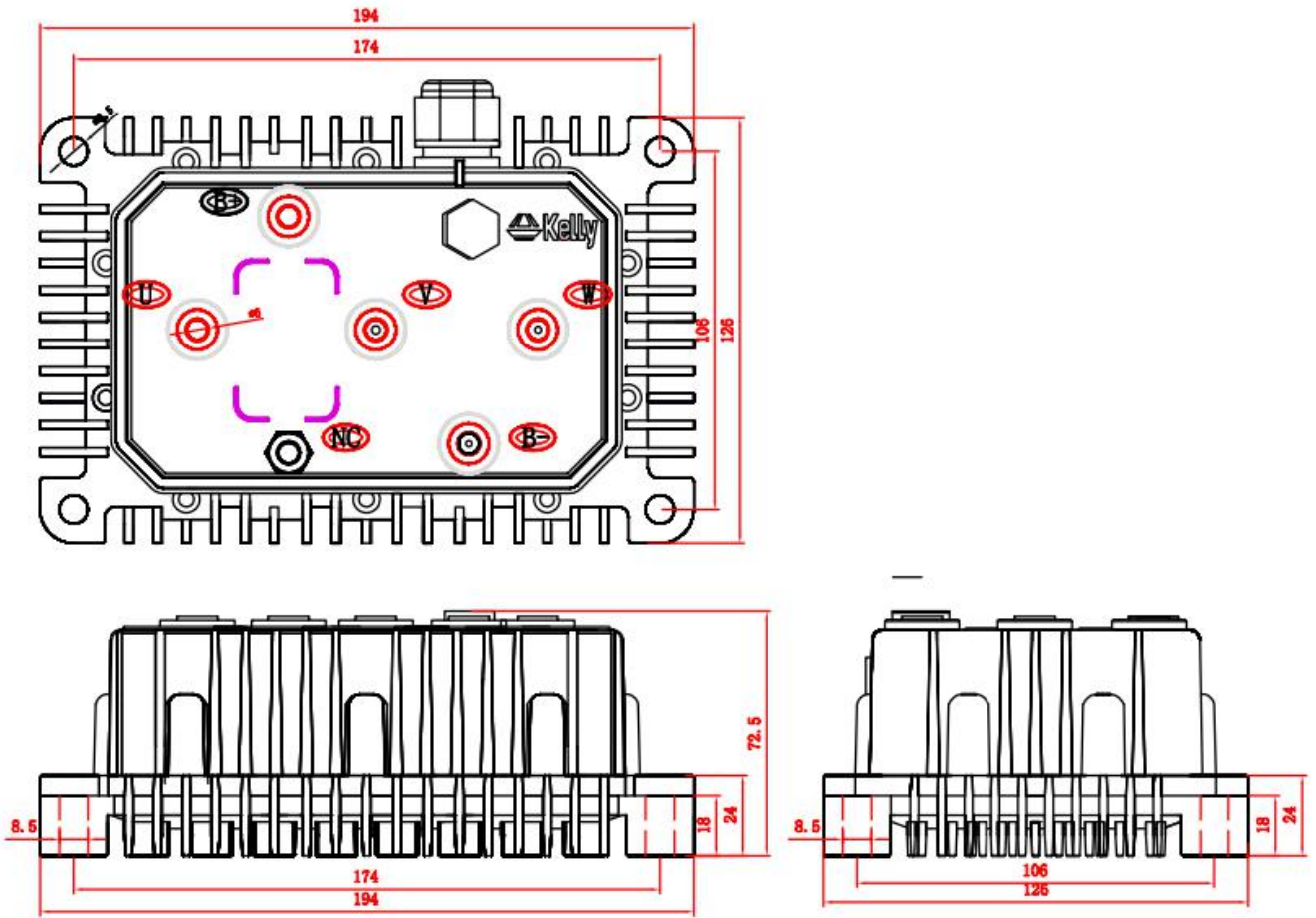

Figure 3: KVDxx18N mounting holes' dimensions (dimensions in millimeters)

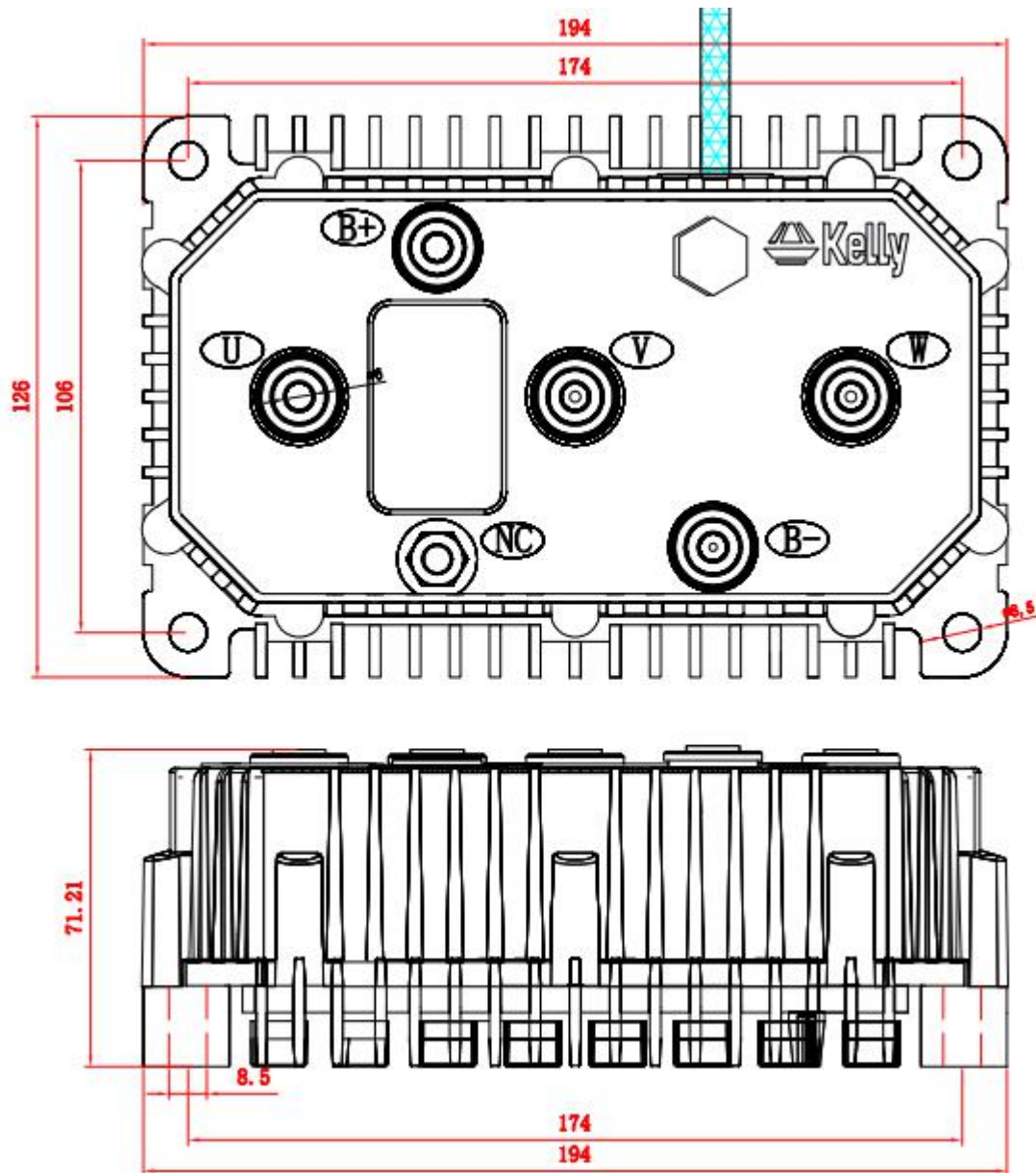

Figure 4: KVDxx30N mounting holes' dimensions (dimensions in millimeters)

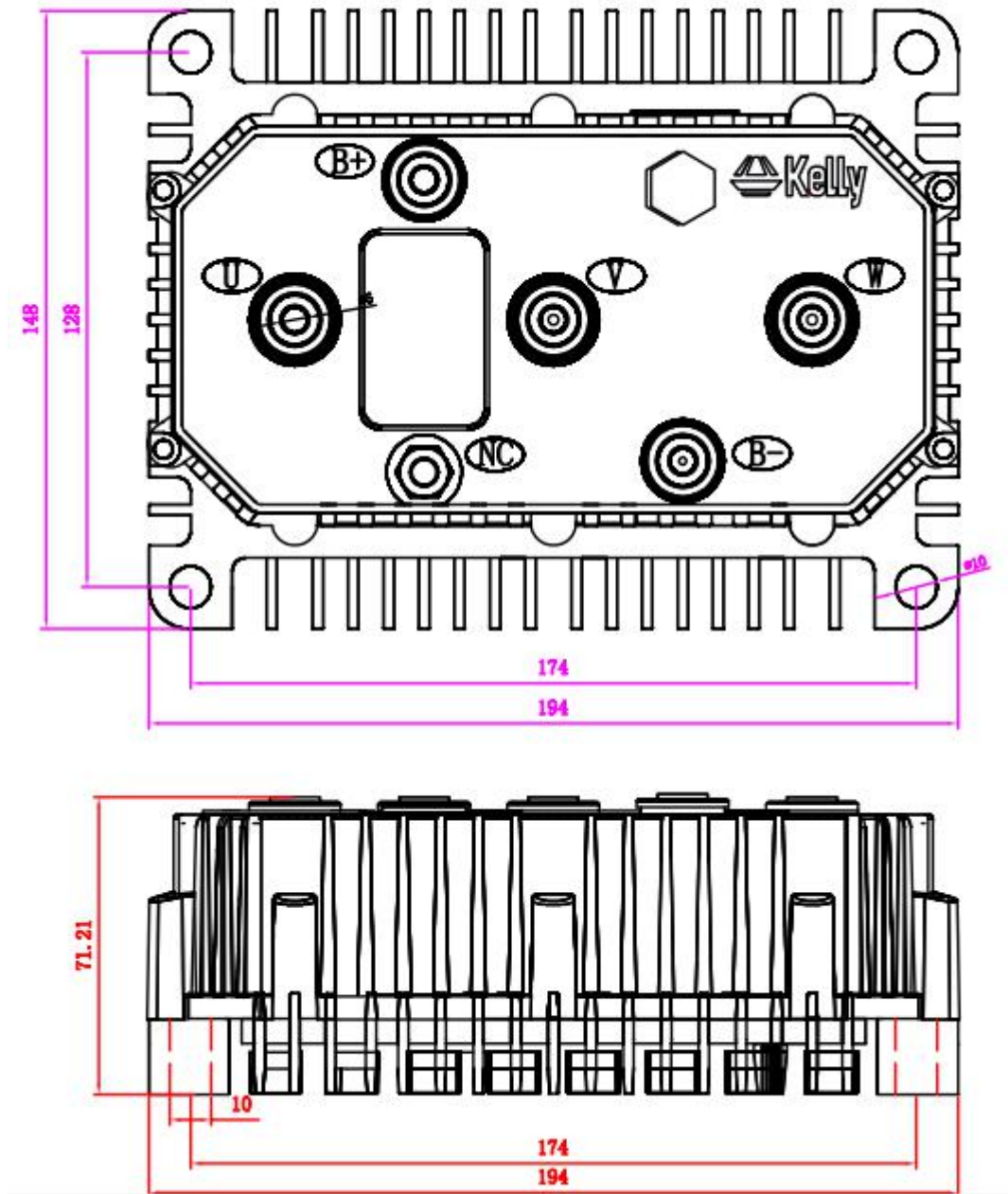

Figure 5: KVDxx45N mounting holes' dimensions (dimensions in millimeters)

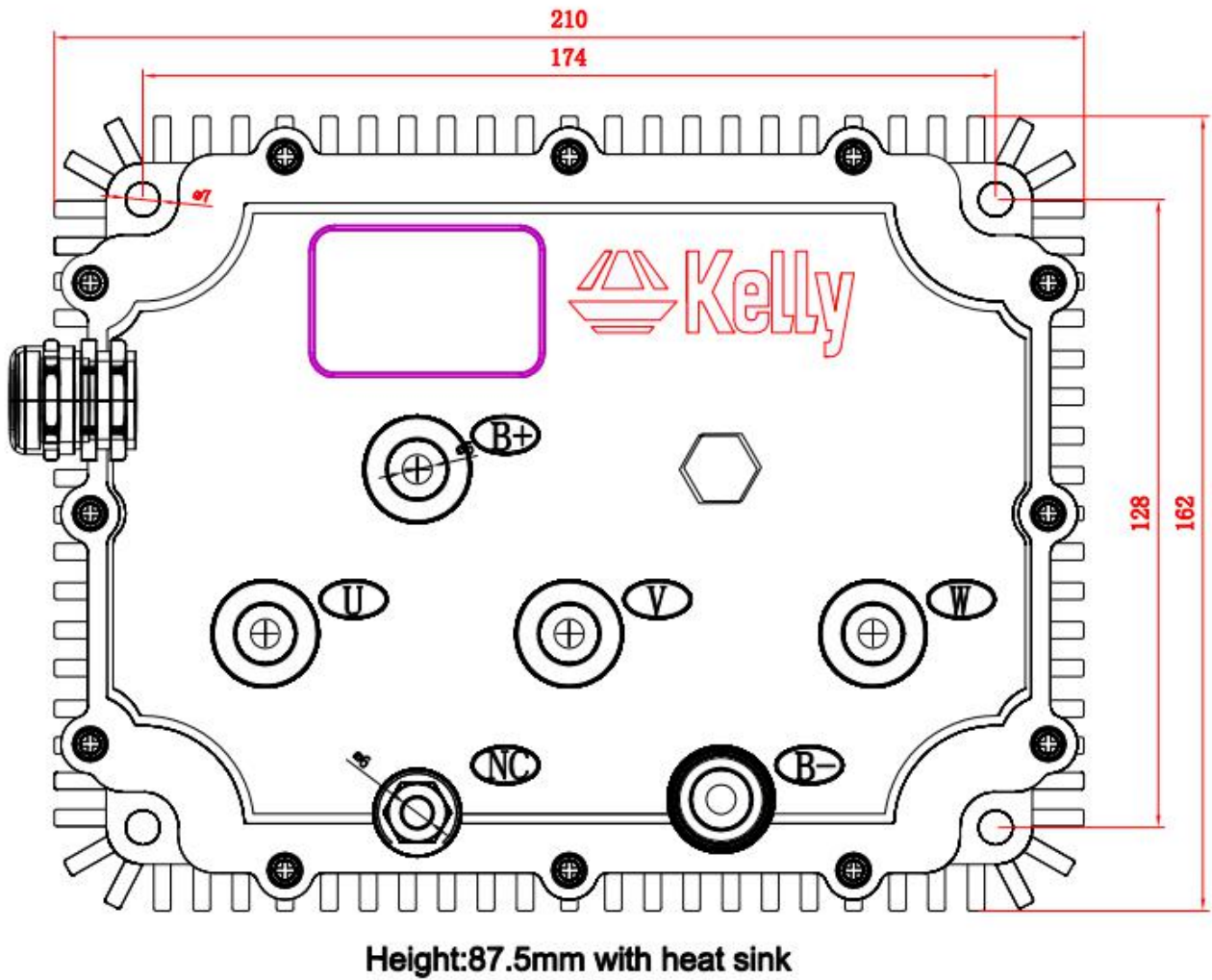
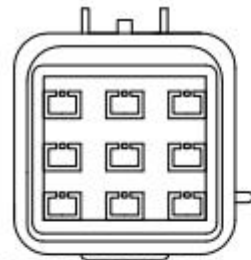

Figure 6: KVD7250N mounting holes' dimensions (dimensions in millimeters)

## 3.2 Connections

### 3.2.1 Pin definition of KVD-N/NX Controller



DJ7091Y-2.3-11  
See from output side

Orange REV-SW (14)	Black GND (6)	White FWD (12)
Red 12V (11)	Yellowish 12V Brake (25)	Blue ECO (22)
Greenish CAN_H (33)	Pink PWR (7)	Brownish CAN_L (34)



DJ7091Y-2.3-21  
See from output side

Gray Foot_SW (15)	Green Throttle (3)	
Black GND (20)	D-Gray Meter (8)	
Purple 5V (4)	Brown Brake_AN (2)	Red 12V (11)



DJ7061Y-2.3-21  
See from output side

Black GND (21)	Raddle Temp (1)	Purple 5V (5)
Yellow Hall A (18)	D-Green Hall B (17)	D-Blue Hall C (16)

- 1,The switch signal is valid to GND or B- signal except the brake switch pin25.
  - 2,12V capacity is low.This 12V only can be used for LED or switch signals.
  - 3,Boost and Brake analog regeneration mode used the same pin as pin2.
- When Boost is disabled in the user program,the pin2 can be used as brake variable regen mode.When Boost is enabled,the brake analog regen mode is inactivated automatically.Both Boost and Brake variable regen mode can not be used at the same time.

Figure 7: waterproof connector

### DJ7091Y-2.3-11 Pin Definition

- (14) REV\_SW: Reverse switch input. Orange
- (6) RTN: Signal return or power supply return. Black
- (12) FWD: Forward switch or High speed switch White
- (11) 12V:12V Source Red
- (25) 12V brake switch. Yellowish
- (22) ECO: Low speed switch input Blue
- (33)CAN-H:Greenish(Optional function)
- (7) PWR: Controller power supply (input). Pink

(34)CAN-L:Brownish(Optional function)

## DJ7091Y-2.3-21 Pin Definition

- (15) Micro\_SW: Throttle switch input. Gray
- (3) Throttle: Throttle analog input, 0-5V. Dark Green
- (1) Temp: Motor temperature sensor input. Raddle
- (20) RTN: Signal return. Black
- (8) Meter: Copy signal of hall sensors. Dark Gray
- (4) 5V: 5V supply output, <40mA. Purple
- (2) Brake\_AN: Brake variable regen or Boost function. Brown

## DJ7061Y-2.3-21 Pin Definition

- (21) RTN:Signal return. Black
- (5) 5V: 5V supply output,<40mA.Purple
- (18) Hall A: Hall phase A. Yellow
- (17) Hall B: Hall phase B. Dark Green
- (16) Hall C: Hall phase C. Dark Blue

### Notes:

1. All RTN pins are internally connected.
2. Meter function is to copy either of hall sensors.
3. Brake Switch to 12V is active. Other switches to GND is active.Open switch is inactive.

### Caution:

- Do not apply power until you are certain the controller wiring is correct and has been double checked. Wiring faults will damage the controller.
- Ensure that the B- wiring is securely and properly connected before applying power.
- The preferred connection of the system contactor or circuit breaker is in series with the B+ line.
- All contactors or circuit breakers in the B+ line must have precharge resistors across their contacts. Lack of even one of these precharge resistors may severely damage the controller at switch-on.

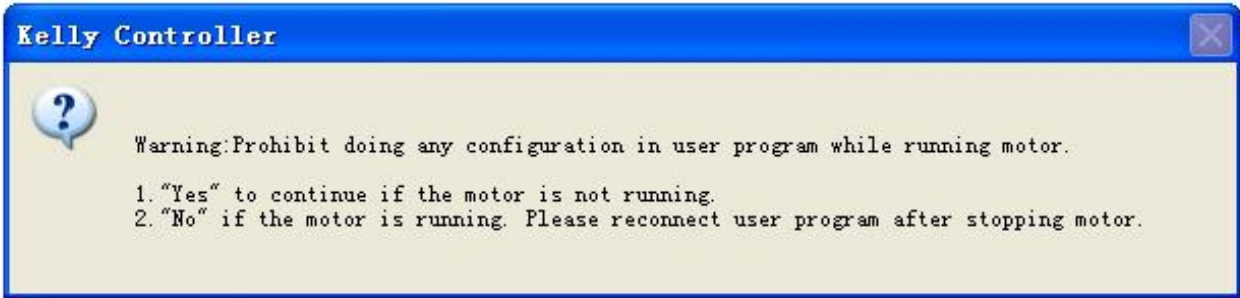

### 3.2.2 Standard Wiring of KVD-N Controller

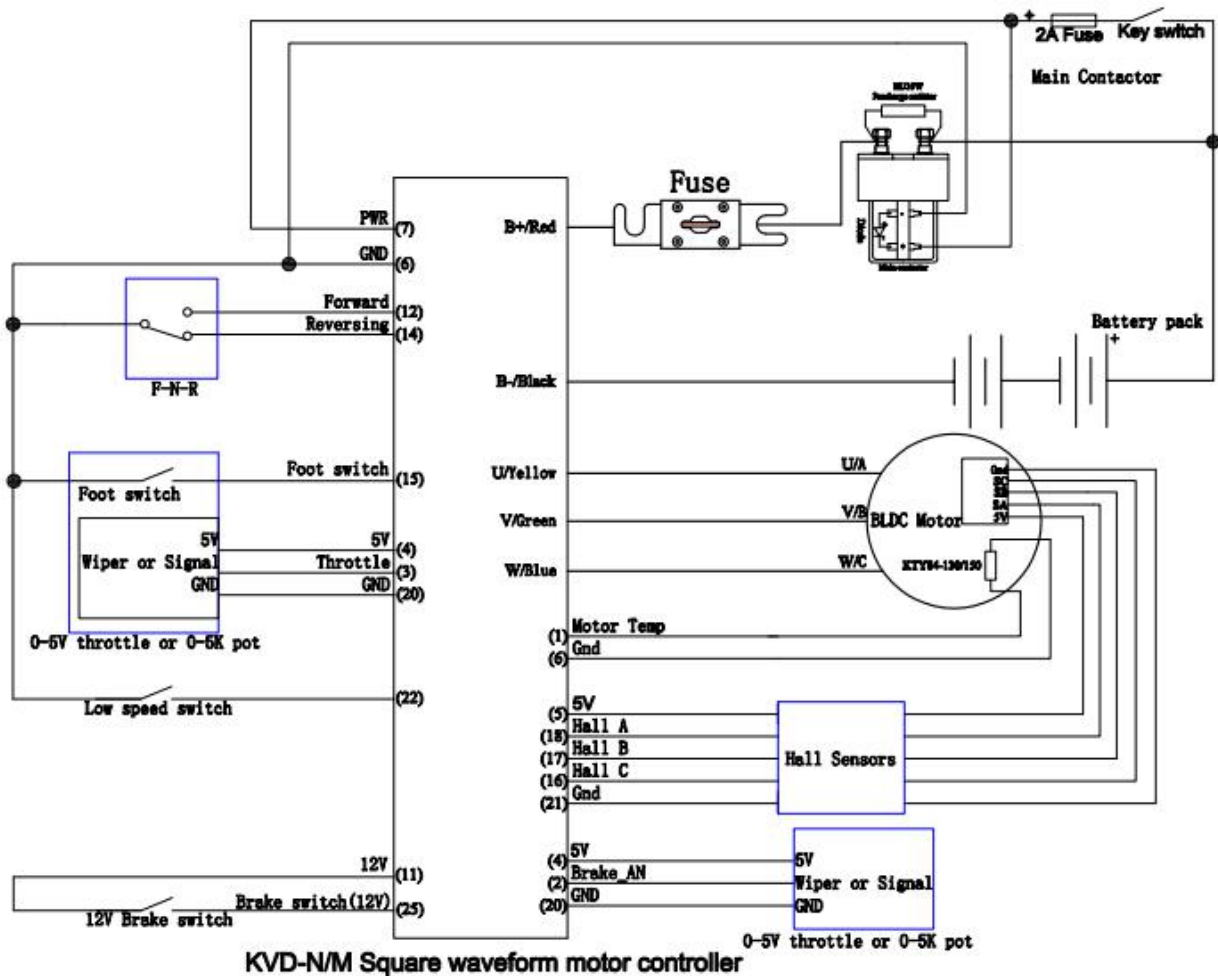

Figure 8: KVD-N controller standard wiring(F-N-R control)  
(Battery voltage can be used for controller supply)

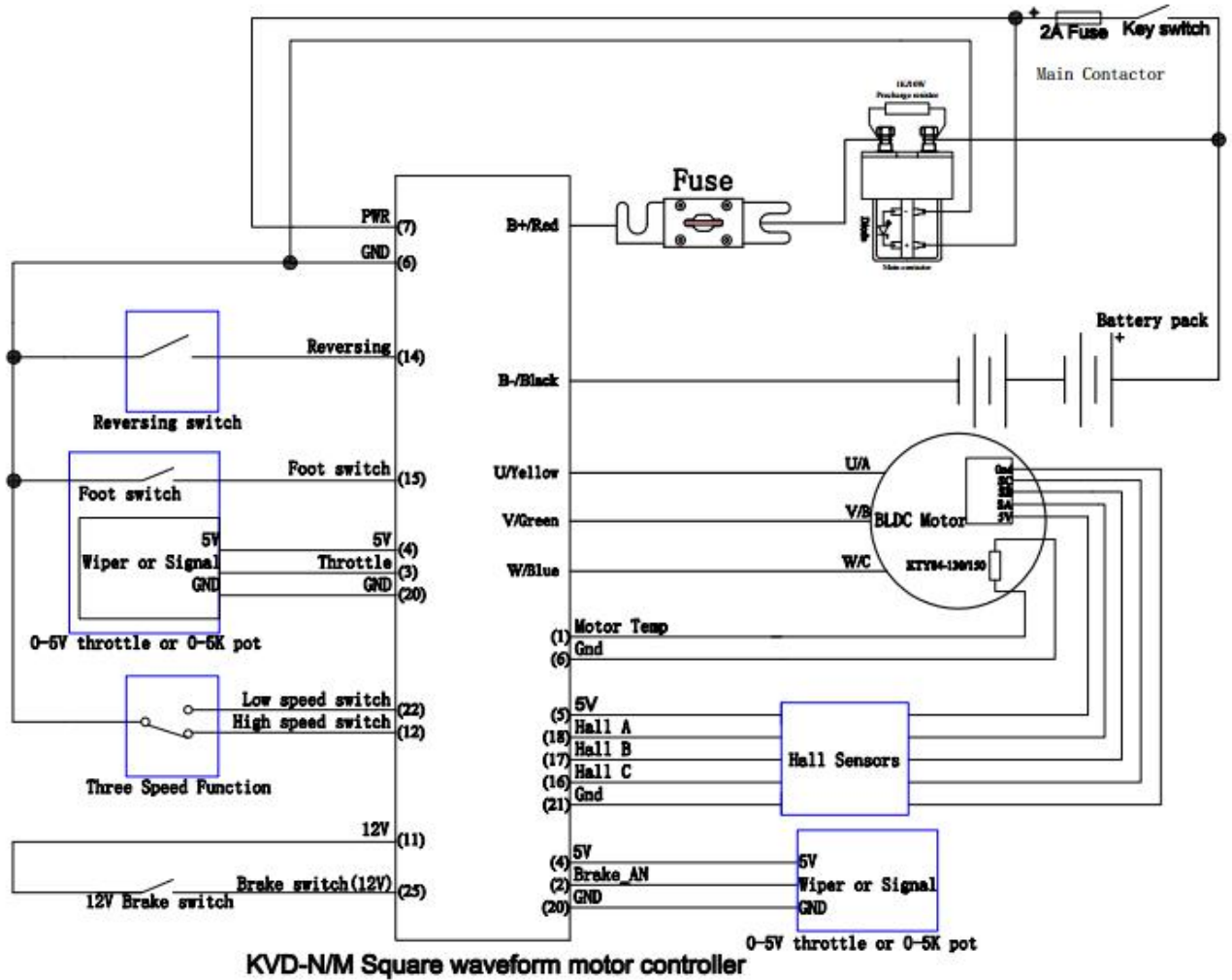

Figure 9: KVD-N controller standard wiring(Three speed function control)  
(Battery voltage can be used for controller supply)

### 3.2.3 Optional wiring of KVD-N/M/H/8080H controller

The 12V input signal of the pin supplies the second braking function of the controller.

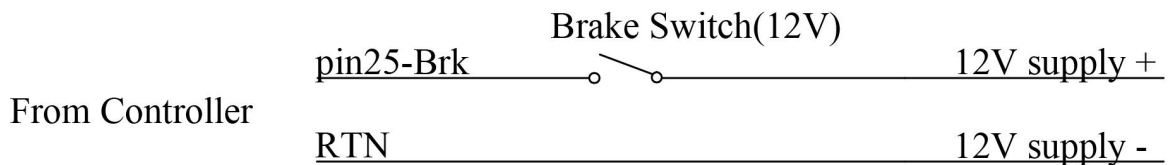
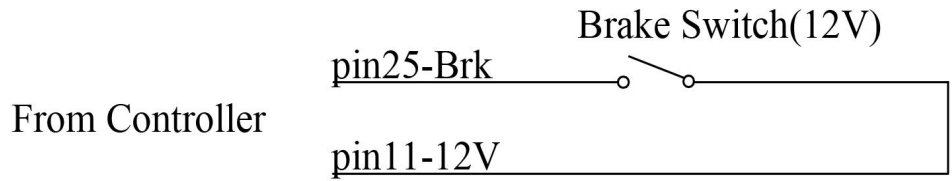
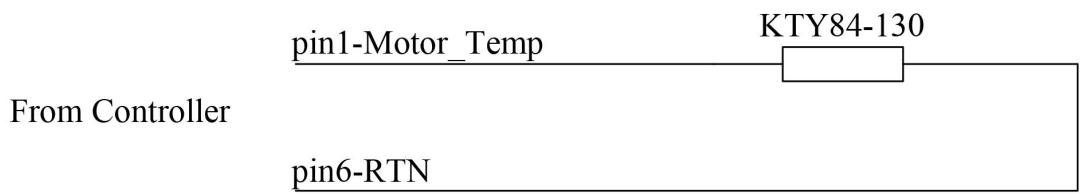

Figure 10: Wiring of brake switch(12V): 12V is provided by external source.





**Figure 11:** Wiring of brake switch(12V): 12V is provided by KVD controller on pin11

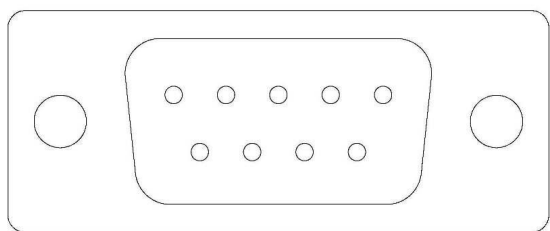

**Figure 12:** Wiring diagram for motor temperature sensor

**NOTE:**The motor temperature sensor and low level brake switch used the same I/O port on pin1.Both functions can not be used at the same time.KVD controller can support KTY84-150 and KTY84-130 thermistors.

**3.2.4 Communication Port**

A 4pin connector to RS232 port is provided to communicate with host computer for calibration and configuration.



**Figure 13:** RS232 Interface on 4pin connector to RS232 converter

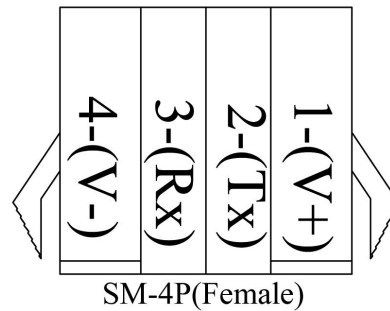

**Figure 14:** SM-4P connector for communication interface on KVD controller

### 3.3 Installation Check List

Before operating the vehicle, complete the following checkout procedure. Use buzzer code as a reference as listed in Table 1.

**Caution:**

- Put the vehicle up on blocks to get the drive wheels off the ground before beginning these tests.
- Do not allow anyone to stand directly in front of or behind the vehicle during the checkout.
- Make sure the PWR switch and the brake is off
- Use well-insulated tools.
- Prohibit trying to connect the controller to user program while the motor is still running, let alone change the settings in the user program.

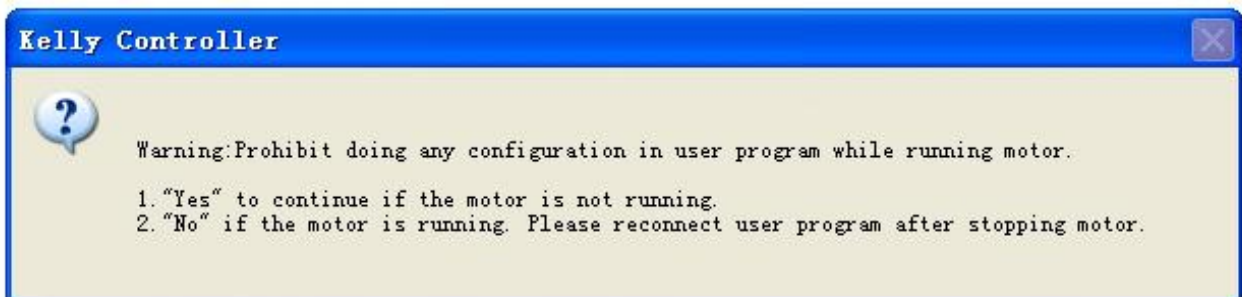

- Make sure the wire is connected correctly
- Turn the PWR switch on.
- The fault code will be detected automatically at restart.
- With the brake switch open, select a direction and operate the throttle. The motor should spin in the selected direction. Verify wiring or voltage and the fuse if it does not. The motor should run faster with increasing throttle. If not, refer to the Table 1 code, and correct the fault as determined by the fault code.

- Take the vehicle off the blocks and drive it in a clear area. It should have smooth acceleration and good power.

## Chapter 4 Programmable Parameters

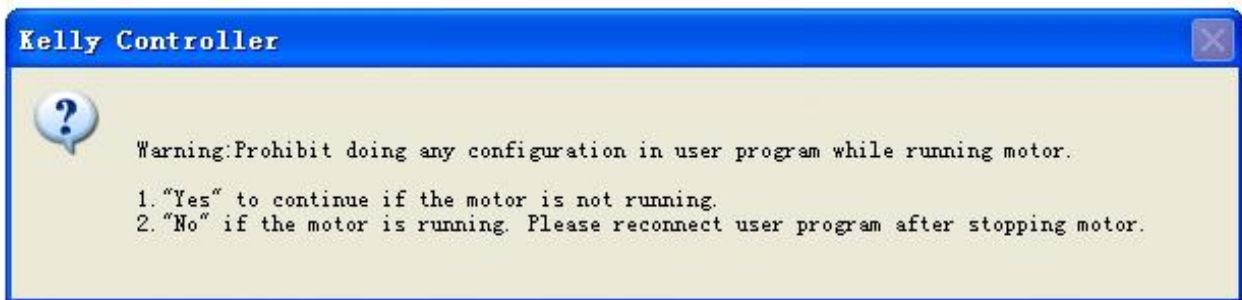

KVD Configuration program allow users to set parameters according to the vehicle actual working environment so as to be at its best.

The default parameters of the controller are not recommended for all applications. Make sure set the proper parameters before making any test to avoid danger.

Customers can do program on PC software or Android App. The Android Tablet is preferred. First of all, people need to do Identification angle function for KVD controller before running the motor. The controller needs to be connected to batteries, motor and throttle before Identification operation. That is to say, it is not enough to connect only power supply (PWR=pin7) to batteries for Identification Angle operation.

Please download the instruction how to use Identification angle function from our website.  
[www.kellycontroller.com/support.php](http://www.kellycontroller.com/support.php)

### 4.1 Vehicle setting



(1)Low Voltage

Value range: Please see Figure 4.2

Functional description: Controller will not operate when battery voltage is lower than the value so as to protect battery.Low voltage setting is the same as Undervoltage setting.

Suggestion: Set according to the practical situation.

(2)Over Voltage

Value range: Please see Figure 4.2

Functional description: Controller will not operate when battery voltage is higher than the value so as to protect battery and controller.

Suggestion: Set according to the practical situation.

Controller Rated voltage	Under Voltage Range (V)	Over Voltage Range(V)
24V	20~30	20~30

60V	40~80	40~80
72V	40~90	40~90

Figure 4.1

## (3)Accelerate Speed or Throttle Up/Down Rate

Value range: 10~100

Functional description: Pedal AD Sampling Frequency, a lower value means a shorter sampling period and a faster respond rate.

Suggestion: Set according to the practical situation, factory default is 30.

(4)TPS Type: Throttle Type, 0:None;1:0-5V 3-wire 0-5K pot,5K is normal,2K-20K can be used;2:Hall active throttle or pedal;3:2-wire 0-5K pot. Range: 0~3

(5)TPS Dead Low: TPS Dead Zone Low. Range: 0~100

Functional description: Set throttle effective starting point

Suggestion: Set according to the practical situation, factory default is  $40\% * 5V / 2 = 1.0V$ . The actual setting is Setting Value/2. For example, if you fill 60, the actual effective starting position is  $60\% / 2 = 30\% * 5V = 1.5V$ .

(6)TPS Dead High: TPS Dead Zone High. Range: 100~200

Functional description: Set throttle effective ending point

Suggestion: Set according to the practical situation, factory default is  $160\% * 5V / 2 = 4.0V$ . The actual setting is Setting Value/2. For example, if you fill 160, the actual effective ending position is  $160\% / 2 = 80\% * 5V = 4.0V$

(7)TPS 1\_4V\_Low Err: Hall active pedal, if lower than the value, report the fault of TPS Type. Range: 0~20

(8)TPS 1\_4V\_High Err: Hall active pedal, if higher than the value, report the fault of TPS Type. Range: 80~100

These two settings are only useful when the throttle type is fill at 2.

As you may know, the output of hall throttle from Kelly is about from 0.86V to 4.2V.

Our controller will report 3.3 error code if the output of hall throttle is below 0.5V or above 4.5V by default.

The controller will think the hall throttle is shorted or damaged if the output is beyond the range from 0.5V to 4.5V.

You can adjust the threshold voltage below or above 0.5V. The controller will report the 3.3 code to protect the system according to different types of hall throttle.

Because there are many different hall throttle suppliers in the world. The initial output can not be always in the range of 0.5V to 4.5V.

But it doesn't make any differences if you choose 0-5V or 3-wire pot for the throttle type. That is to say, these two settings are only useful for hall active throttle or pedal when you chose throttle type at 2.

As the same goes, it is valid to adjust the high threshold voltage above 4.5V or below 4.5V. Usually the hall output voltage is 4.2V Max. If you adjust it to lower value which is near 4.2V, it may trigger the error code in normal way.

In simple, if output voltage of hall throttle is below TPS 1\_4V\_Low Err or above TPS 1\_4V\_High Err setting, the controller will report 3-3 error code. For example, we set them at 1 and 94 by default. So the TPS 1\_4V\_Low Err is at  $1\% * 5V = 0.05V$ . As the same goes, the TPS 1\_4V\_High Err is at  $94\% * 5V = 4.7V$ . If the output of hall throttle signal is below 0.05V or above 4.7V, the controller will report 3-3 error code.

#### (9) Brake Type

Brake sensor type for brake variable regen mode

Value range: No used, 3-wire resistive pot, hall active throttle.

Functional description: Set brake sensor type. Please choose "Not Used" if analog brake sensor isn't used. You have to turn on brake switch to start regen, then vary regen with the signal.

Suggestion: Set according to the practical situation, factory default is "Not Used".

#### (10) Brake Dead Low: Brake Sensor Starting Point

Value range: 0~100%

Functional description: Set brake sensor effective starting point

Suggestion: Set according to the practical situation, factory default is 40%. The actual setting is Setting Value/2. For example, if you fill 60, the actual effective starting position is  $60\% / 2 = 30\% * 5V = 1.5V$ .

#### (11) Brake Dead High: Brake Sensor Ending Point

Value range: 100%~200%

Functional description: Set brake sensor effective ending point

Suggestion: Set according to the practical situation, factory default is 160%.

The actual setting is Setting Value/2. For example, if you fill 160, the actual effective ending position is  $160\% / 2 = 80\% * 5V = 4.0V$

(12) Max Rev Speed %: The reverse speed of the percentage of maximum speed. Range: 30~100 By default, it is set at 100%. Only this item can be used to change the speed in reversing direction, nothing else.

(13) Max Forw Speed %: The forward speed of the percentage of maximum speed. Range: 30~100 By default, it is set at 100%

#### (14) 2-Gear Forwspeed and 3-Gear Forwspeed

Range: 0~100

Both F-N-R control and three speed function used the same pin12. Needless to say, we can not use both functions at the same time. Three Gears switch is supposed to enable F-N-R control. When this item is enabled, we can not use three speed function, vice versa.

ECO-pin22 is used for two speed function. 2-Gear Forwspeed is used to adjust the speed percentage value when you use two speed function on pin22.

Two Speed Drive

When you enable three speed function,you can use pin22 as low speed function and pin12 as high speed function,we may just need to enable the three speed function in the user program.

Three Speed Drive

In this case,both 2-Gear Forwspeed and 3-Gear Forwspeed are used for adjusting the different speed percentage values for three speed functions.

(15)Boost Function

Value range: Enable and Disable

Functional description: Please see figure 4.3

Suggestion: Set according to the practical situation, factory default is Disable.

(16)Economy Function

Value range: Enable and Disable

Functional description: Please see figure 4.3

Suggestion: Set according to the practical situation, factory default is Disable.

Configuration		Pin Status	Output Current (Max Current: I_max)
Boost	Economy	BRK_AN(2)	
Disable	Disable	x	0~I_max
Disable	Enable	ON	0~(I_max * 50%)
		OFF	0~I_max
Enable	Disable	ON	I_max
		OFF	0~(I_max * 60%)

Figure 4.2

Note: Boost Function, Economy Function and Half Current In Reverse can not be used at the same time.

Boost and Economy used the same pin on pin2.Obviously the brake analog port can not be used as brake variable regen mode if Boost or Economy is enabled in the user program.

(17)Rev\_H Curr:Half Current In Reverse

Value range: Enable and Disable

Functional description: If enabled, the max output current will be limited to half at reversing.

Suggestion: Set according to the practical situation, factory default is Disable.

(18)Brake H-Pedal:Releasing Brake High Pedal Disable

Value range: Enable and Disable

Functional description: If enabled, the controller will detect the current pedal status when release the brake. If throttle got effective output, the controller will report fault and not operate.

Suggestion: Set according to the practical situation, factory default is Enable.

(19)Cruise Control:Value range: Enable and Disable

If enable,if you hold throttle at certain position about 5-6 seconds,the controller will get into Cruise control.

Release throttle and turn the throttle again or turn on the brake switch will make the Cruise control quit.

Suggestion:factory default is Disable.

(20)Joystick function:

If enable,the controller can drive the motor on two directions without using any reversing switch. Just one single throttle can drive the motor on forward and reversing direction.

The stick shift throttle firmware can be called wig-wag or joystick operation.It is only a software function.Usually It is useful for electric boat project.You still can use the common 0-5K pot or 0-5V throttle for the controller.If you don't choose the joystick,you operated the throttle in this way.The motor speed will increase when the throttle is from 0V to 5V.

If you enable joystick for this controller in user program,you will start the motor from 2.5V position.2.6V to 5V is forward.2.4V to 0V is backward.

2.4V to 2.6V is the throttle dead zone.Customers can adjust the throttle dead zone in user program also.

Please note the common throttle will spring back to original position if you release the throttle.

Suggestion:factory default is Disable.

(21)Reduce Noise

Range:Enabled or Disabled.

This function is used try to reduce the noise at the starting up.

(22)Foot Switch

Value range: Enable and Disable

Functional description: If enabled,the foot switch will be activated.The controller will not accept the throttle signal if the foot switch is turned off. Please see figure 4.3.

Suggestion: Set according to the practical situation, factory default is Disable.

Configuration		Pin Status			Running Status
Forward Switch	Foot Switch	FWD_SW (12)	REV_SW (14)	Foot (15)	
Enable	Disable	OFF	OFF	x	Neutral
		OFF	ON	x	Reverse
		ON	OFF	x	Forward
		ON	ON	x	Neutral
Disable	Enable	x	OFF	OFF	Can't operate
		x	ON	OFF	Can't operate
		x	ON	ON	Reverse
		x	OFF	ON	Forward
Disable	Disable	x	OFF	x	Forward



		x	ON	x	Reverse
--	--	---	----	---	---------

Note: X means can be on or off

**Figure 4.3**

(23)Brake regen switch

Range:Enabled or disabled

This function is used to enable the brake switch regen mode.

(24)Three Gears switch:It is used for function of F-N-R control.

Please check the wiring diagram in the manual for F-N-R control which is Forward,Neutral and reversing control.

Suggestion: Set according to the practical situation, factory default is Disabled.

(25)ABS:Avoid locking when braking.It also can be used to prevent the regen quit automatically at low speed range.

(26)Start-up H-Pedal:

Value range: Enable and Disable

Functional description: If enabled, the controller will detect the current pedal status at power up. If throttle got effective output, the controller will report fault and not operate.

Suggestion: Set according to the practical situation, factory default is Enable.

(27)Smooth

Here is the explanation for smooth setting.

We added smooth control in the user program.

It is used to set up the throttle map by customers.

The deflection point will divide the low speed and high speed on the throttle map.

We added the smooth control parameters in another page of user program..

When you enable the smooth function,you will see five more parameters in Control Page.

You can adjust the low speed acceleration and deceleration rate,and high speed acceleration and deceleration rate in the user program.

The inflection point is at the joint of low speed and high speed.

Step Percent=Inflection Point

Accel L-Delta=Low Acc rate

Decel L-Delta=Low Dec rate

Accel H-Delta=High Acc rate

Decel H-Delta=High Dec rate

Step Percent	<input type="text" value="10"/>
Accel L-Delta	<input type="text" value="100"/>
Decel L-Delta	<input type="text" value="127"/>
Accel H-Delta	<input type="text" value="100"/>
Decel H-Delta	<input type="text" value="127"/>

Usually Step Percent is set at 10 by default.

Low Acc rate is 100

Low Dec rate is 127

High Acc rate is 100

High Dec rate is 127

The deflection is used to define the point for low speed and high speed. We assume the max inflection point is MAX.

For example, if we set up the inflection point at 10, we think the range below 10/MAX point is low speed area, the high speed range is above 10/MAX.

When you adjust the inflection value, you can determine which point is the joint for low speed and high speed range.

Different motor or motorcycle will affect the value of MAX. I can not let you know the accurate rate.

So we can accelerate and decelerate the motor at low speed range and high speed range.

Low Acc rate is Low speed range acceleration performance rate. If the value is high, that is to say, the controller will accelerate the motor very fast at low speed range. If the value is low, the acceleration is slow or gradual.

Low Dec rate is Low speed range deceleration performance rate. If the value is high, that is to say, the controller will decelerate the motor fast, the motor will stop quickly after throttle is released.

High Acc rate is High speed range acceleration rate.

High Dec rate is High speed range deceleration rate.

The explanation is the similar as above. They only just located on high speed range.

You can assume the value is just the response time. There is no unit for the value. Sorry for that.

Different motor, cars will provide different results under the same value.

Customers need to tune up the parameters according to every vehicle data in real testing.

(28) Two speed drive

Can check pin 14 for reference.

It is used to activate the two speed function on pin 22.

(29) Inverse output: If the direction is not what you expected, this function can change the default direction. But you need to use auto identify function to find the correct hall/phase combination first.

(30) Phase Auto\_Dis: This is Auto Identify function.

Because KVD can provide the auto-Identify function for customers to find the correct hall/phase combination quickly. It can improve the efficiency greatly and save much wiring time.

1, You need to keep the motor off the ground to do this testing.

- 2, Please connect the controller to user program.
- 3, Please click the Phase auto Discern item in the first picture of user program.
- 4, Please Click write button after enable Phase auto discern
- 5, Please reset the power supply to activate the setting. The motor will try to run the motor to find the correct timing after power supply is turned on again.  
So the motor will run a little bit by itself. The red LED will be solid on in this case. When the Auto identify is finished, the red LED is off and Green LED is on.  
Then please reset the power supply again.
- 6, Then you can turn the throttle to rotate the motor.
- 7, If the direction is not what you expected, you may enable the Inverse output in the user program.
- 8, Please reset the power supply to activate the setting again. That is to say, you need to turn off the power supply and turn on it again.
- 9, Then the direction of the motor is what you expected.

(31) Copy Hall: If disabled, the pin8(meter) is used as current meter output function. If Copy hall item is enabled in the user program, the pin8 is used as speed output signal(copy one of hall sensor signals)

(32) Anti-Slip: It is used to prevent the motor running faster and faster under gravity on slope after the throttle is released completely if you enable this function.

(33) Three speed function. Please check point 14 as reference. Once enabled, it worked in this way.

Pin22 is low speed function

Pin12 is high speed function.

If both switches are not activated, the controller will run in medium speed mode. Each speed range can be adjusted between 30%-100%.

## 4.2 Motor Setting

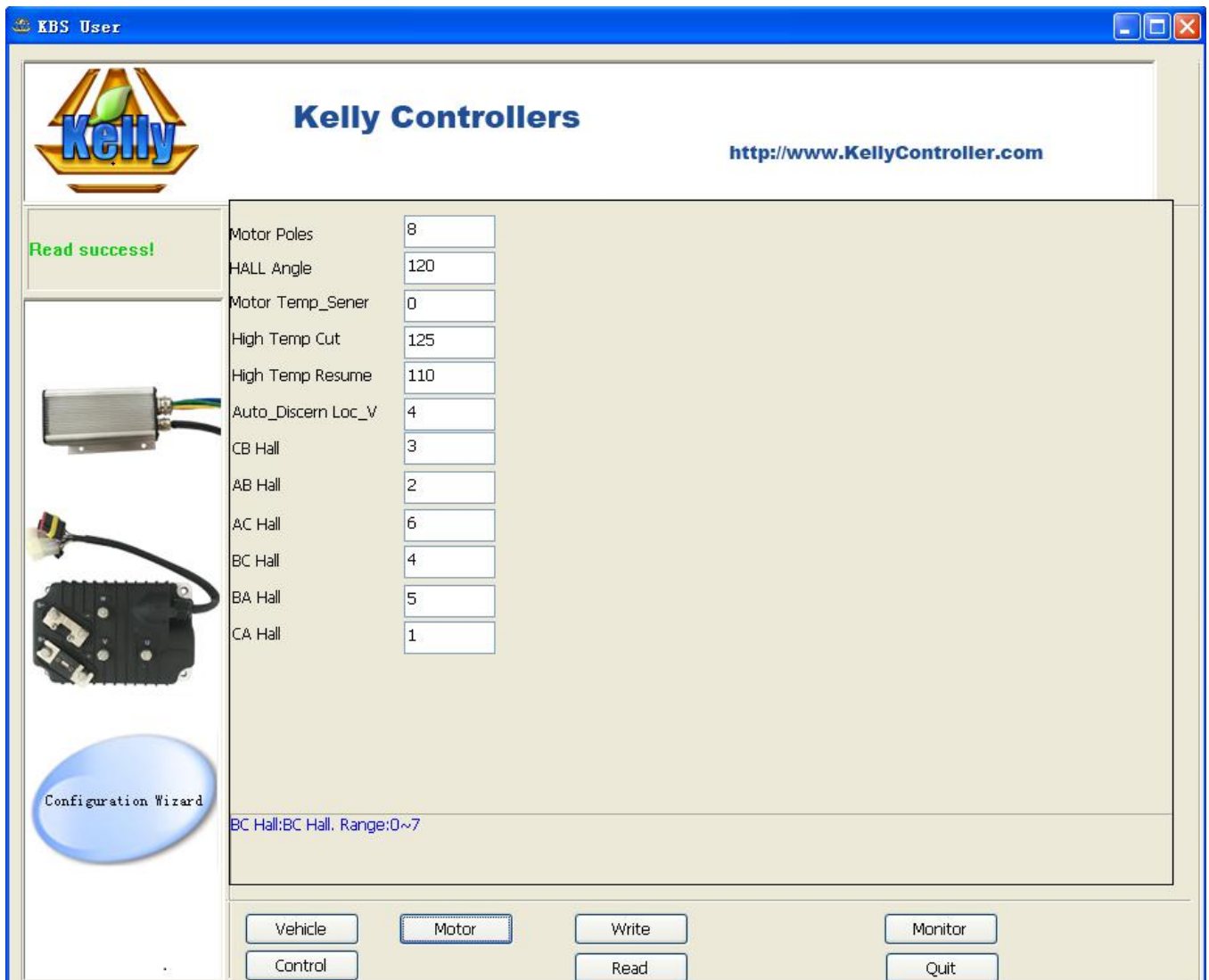

### (1)Motor Poles

Value range: 0-254(The number must be even type)

Suggestion: Set according to the number on nameplate of the motor

### (2)Hall Angle:Hall Sensor Type

Value range: 60 degree and 120 degree

Functional description: Set according to your motor hall sensor type.

Suggestion: Set according to the practical situation.

### (3)Motor Temperature Sensor

Value range: 0-2

Functional description: If use motor temperature sensor and enable this function, Controller Stop Output Temperature and Controller Resume Output Temperature can be configured so as to achieve real-time protection on the motor.

0:None;1:KTY83-122;2:KTY84-130/150

Suggestion: Set according to the practical situation.

(4)Controller Stop Output Temperature

Value range: 60°C~170°C

Functional description: Controller will stop output if motor temperature reaches the set value.

Suggestion: Set according to the practical situation.

(5)Controller Resume Output Temperature

Value range: 60°C~170°C

Functional description: Controller will resume output if motor temperature reaches the set value.

Suggestion: Set according to the practical situation.

Note: Thermistor is optional. Default to KTY83-122 OR KTY84-130/150.

(6)Auto-Discern Loc\_V:This value is specified for how many volts will be used during auto identify function.

Range:0-10

(7)CB hall,AB hall,AC hall,BC hall,BA hall,CA hall

Range:0-7

These values will be generated automatically after the auto identify operation is finished successfully.

### 4.3 Control Setting



**(1)Control Mode**

Value range: Torque/Balanced/Speed(0-2)

Functional description: Set controller output mode. Torque mode brings faster response of the load and good acceleration. Balanced mode brings fast response of the load and wide speed adjusting range. Speed mode brings smooth operation and wide speed adjusting range.

Suggestion: Set according to the practical situation, factory default is Torque mode.

**(2)Start-up Wait Time:Start-up Delay Time**

Value range: 0-20

Functional description: When power is on, set delay time to wait for stabilization of B+, a higher value means a longer delay time.

Suggestion: Set according to the practical situation, factory default is 5=0.5s.

**(3)Bus Current Percentage:Max Battery Current setting**

Functional description: Set max battery current so as to protect battery. A lower value means a lower battery output current and better protective effect. But excessively low value will affect acceleration.

Suggestion: Factory default is 50%.

(4)Phase Current Percent: Phase Current Percent. Range: 20~100

Functional description: The max motor current is (The Value \* Peak Current of the Controller).

Suggestion: Factory default is 100%.

(5)Max Regen Current

Value range: 20%~100%

Functional description: Max regen current with max signal from brake sensor.

Suggestion: Set according to the practical situation, factory default is 100%.Actual value is  $100\%/2=50\%$ .

(6)TPS regen Current

Releasing Throttle Regen Mode and Max Allowed Regen Current

Value range: 0~100

Functional description: Set the max allowed regen current in releasing throttle regen mode.

Suggestion: Set according to the practical situation, factory default is 20.

(7)Brake Switch Regen current

Value range: 0-100

Functional description: If enabled, turn off throttle and turn on brake switch will start regen.

Suggestion: Set according to the practical situation.

(8)LVWeak Start Volt:The controller will start to reduce the current to protect the battery when the battery voltage hits this LVWeak Start Volt setting.Factory default is 18V

(9)LVWeak Percent:When the LVWeak start volt is hit,the output current will be limited to this value setting.For example,if we fill it at 80,when the voltage is near 18V,output current is only 80% of driving.If we fill it at 100,that is to say,there is no low voltage weakening current function.

## 4.4 Monitor Screen

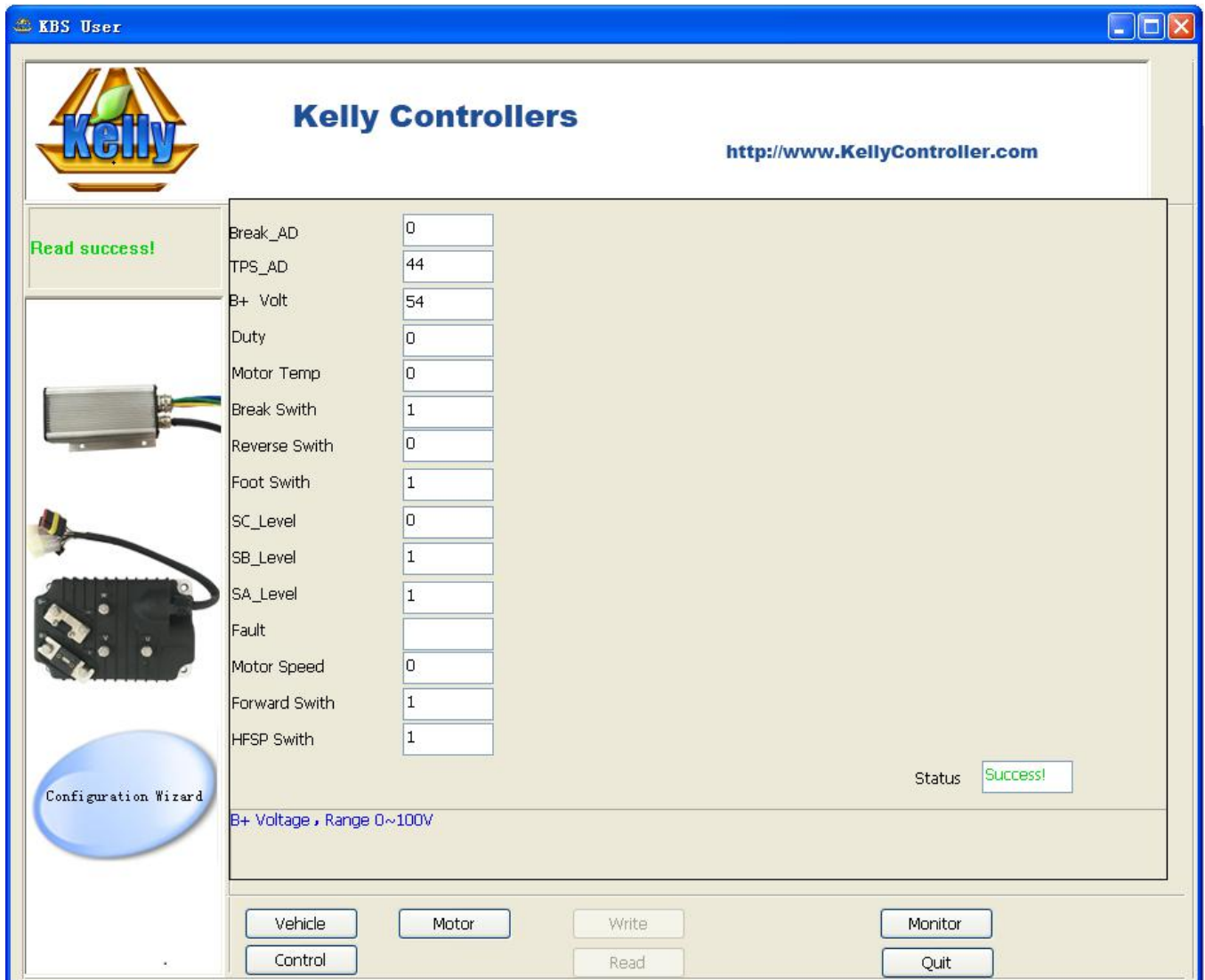

The monitor screen can provide the status of each I/O port. It can help user or seller analyse the root cause of the problem quickly.

(1) Break\_AD: It is used to display the value of brake analog port pin2.

Range: 0-255AD

(2) TPS-AD: It is the value of throttle signal on pin3

Range: 0-255AD

(3) B+ Volt: The voltage of batteries.

(4) Duty: Duty Cycle

(5) Motor Temp: The temperature of the motor

(6) Break switch: Brake switch on pin13

(7) Reversing switch

(8) Foot switch: Throttle switch or microswitch in throttle or foot pedal

(9) SC/SB/SA Level: The status of hall sensors

(10) Fault: Error message



(11)Motor Speed:Show the motor RPM

(12)Forward switch:The forward switch pin12

(13)HFSP Switch:Low speed switch on pin22

As of the status of these switch signals,when the value is 1,the port is not connected to GND or not activated.When the value is 0,that is to say,the switch signal is activated or connected to GND.

**Note:** Thermistor is optional. Default to KTY84-130/150 or KTY83-122

### 4.5 Simple wiring diagram for Auto Identify function

1,Please hook up the controller for Auto Identify operation according to the wiring diagram below.Please make sure there is no load on the motor shaft before starting the programming.

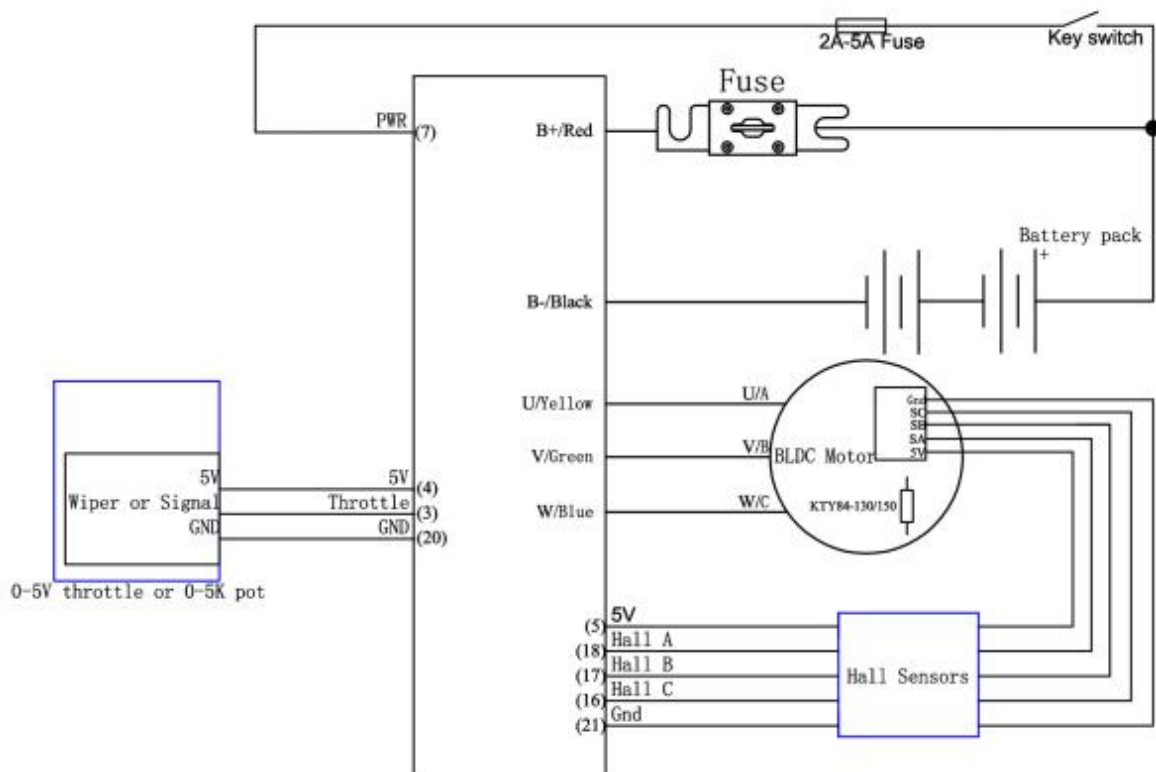

2,Please connect the controller to user program by using an USB to RS232 cable and SM-4A DB9(RS232) Converter.

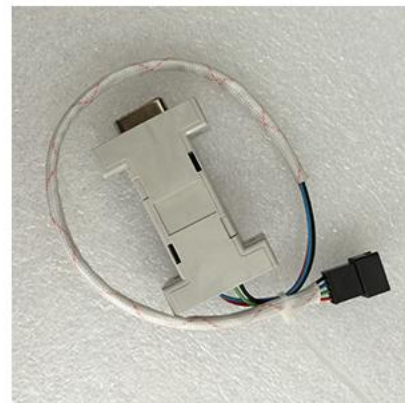

Customers also can use a Z-TEK USB to RS232 cable and SM-4A DB9(RS232) Converter to connect the controller to an Android Tablet.



The third option is customers can buy our Bluetooth converter to connect the controller to

Android Phone. We don't have to use SM-4A to DB9(RS232) converter any more when you use Bluetooth converter for programming the controller.

3, Please download the controller user program from our website for free.

[www.kellycontroller.com/support.php](http://www.kellycontroller.com/support.php)

Please install the user program in your computer, Tablet or Phone.

4, KVD: Auto Identify=Phase Auto\_Dis

1), Because KVD can provide the auto-Identify function for customers to find the correct combination quickly. It can make the motor run more smooth.

2), You need to keep the motor off the ground to do this testing.

3), Please connect the controller to user program.

4), Please find Phase Auto\_Dis item in Vehicle Part.

5), Please enable Phase Auto\_Dis function in the user program.

6), Please reset the power supply to activate the setting. The motor will try to run the motor to find the correct timing after power supply is turned on again.

So the motor will run a little bit by itself. When the motor stops after a while, the auto identify is finished successfully. You can turn off and on power supply again.

7), Then you can turn the throttle to rotate the motor.

8), If the direction is not what you expected, you may change current status of Inverse output item in the user program.

9), Please reset the power supply to activate the setting again. That is to say, you need to turn off the power supply and turn on it again.

10), Then the direction of the motor is what you expected.

## Chapter 5 Maintenance

There are no user-serviceable parts inside the controllers. Do not attempt to open the controller as this will void your warranty. However, periodic, exterior cleaning of the controller should be carried out.

The controller is a high powered device. When working with any battery powered vehicle, proper safety precautions should be taken that include, but are not limited to, proper training, wearing eye protection, avoidance of loose clothing, hair and jewelry. Always use insulated tools.

### 5.1 Cleaning

Although the controller requires virtually no maintenance after properly installation, the following minor maintenance is recommended in certain applications.

- Remove power by disconnecting the battery, starting with battery positive.
- Discharge the capacitors in the controller by connecting a load (such as a contactor coil,

resistor or a horn) across the controller's B+ and B- terminals.

- Remove any dirt or corrosion from the bus bar area. The controller should be wiped with a moist rag. Make sure that the controller is dry before reconnecting the battery.
- Make sure the connections to the bus bars, if fitted are tight. To avoid physically stressing the bus bars use two, well-insulated wrenches.

## 5.2 Configuration

You can configure the controller with a host computer through either an RS232 or USB port.

- Disconnect motor wiring from controller for configuring existing parameters in the user program or Android APP. If this operation is too much extra job for you, please make sure the motor must be stopped before programming.
- The controller may display fault code, but it doesn't affect programming or configuration. But it will affect the Identification angle operation. Please try to eliminate the error codes before Identification angle operation.
- Use a straight through RS232 cable or USB converter provided by Kelly to connect to a host computer. Provide >+18V to PWR (for a 24V controller, provide >+8V) . Wire power supply return (supply negative) to any RTN pin.
- KVD controller requires a 4pin connector to Kelly RS232 Converter to support the communication. And customers may need a Z-TEK USB cable for Tablet with Android OS.

Customers may download PC software or Android APP to program the controller before running the motor. You may do Identification angle for brushless motor with hall sensors after running the software or Android APP. Every item in the configuration program can show the explanation automatically when you click it.

### Caution:

- Make certain that the motor is connected before trying to run Identification angle function in the configuration software. The controller needs to be connected to batteries, motor and throttle before Identification operation. That is to say, it is not enough to connect only power supply (PWR=pin7) to batteries for Identification Angle operation.
- Configuration software will be regularly updated and published on the website. Please Update your Configuration Software regularly. You must uninstall the older version before updating.
- Please try to use Auto Identify function for motor and hall sensors in the user program

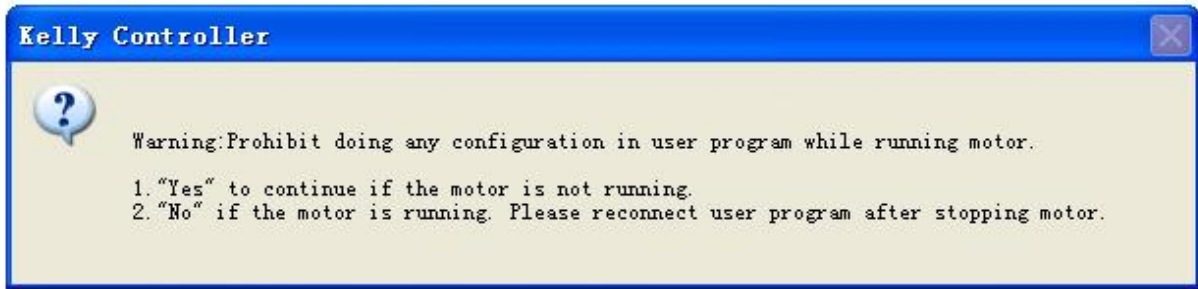

Table 1: Error Codes

**Buzzer Error Codes**

Code	Explanation	Solution
1,1 □ □	Auto Identify Error	<ol style="list-style-type: none"> <li>1. Wrong wiring of motor phase or hall sensors wires</li> <li>2. Please suspend the motor when the identify function in the user program.</li> <li>3. The motor is not balanced well. Please try to capture the waveform of hall/phase timing.</li> </ol>
1,2 □ □□	Over voltage error	<ol style="list-style-type: none"> <li>4. Battery voltage is too high for the controller. Check battery volts and configuration.</li> <li>5. Regeneration over-voltage. Controller will have cut back or stopped regen.</li> <li>6. This only accurate to ± 2% upon Overvoltage setting.</li> </ol>
1,3 □ □□□	Low voltage error	<ol style="list-style-type: none"> <li>1. The controller will clear after 5 seconds if battery volts returns to normal.</li> <li>2. Check battery volts &amp; recharge if required.</li> </ol>
1,4 □ □□□□	Over temperature warning	<ol style="list-style-type: none"> <li>1. Controller case temperature is above 90°C. Current will be limited. Reduce controller loading or switch Off until controller cools down.</li> <li>2. Clean or improve heatsink or fan.</li> </ol>
2,1 □□ □	Motor did not start	Motor did not reach 25 electrical RPM within 2 seconds of start-up. Hall sensor or phase wiring problem.
2,2 □□ □□	Internal volts fault	<ol style="list-style-type: none"> <li>1. Measure that B+ &amp; PWR are correct when measured to B- or RTN.</li> <li>2. There may be excessive load on the +5V supply caused by too low a value of Regen or throttle</li> </ol>

			<p>potentiometers or incorrect wiring.</p> <p>3. Controller is damaged. Contact Kelly about a warranty repair.</p>
2,3	aa aaa	Over temperature	The controller temperature has exceeded 100°C. The controller will be stopped but will restart when temperature falls below 80°C.
2,4	aa aaaa	Throttle error at power-up	Throttle signal is higher than the preset 'dead zone' at Power On. Fault clears when throttle is released.
3,1	aaa a	Frequent reset	May be caused by over-voltage, bad motor intermittent earthing problem, bad wiring, etc.
3,2	aaa aa	Internal reset	May be caused by some transient fault condition like a temporary over-current, momentarily high or low battery voltage. This can happen during normal operation.
3,3	aaa aaa	Hall throttle is open or short-circuit	When the throttle is repaired, a restart will clear the fault.
3,4	aaa aaaa	Non-zero throttle on direction change	Controller won't allow a direction change unless the throttle or speed is at zero. Fault clears when throttle is released.
4,1	aaaa a	Regen or Start-up over-voltage	Motor drive is disabled if an over-voltage is detected at start-up or during regen. The voltage threshold detection level is set during configuration.
4, 2	aaaa aa	Hall sensor error	<p>1. Incorrect or loose wiring or a damaged hall sensor.</p> <p>2. Also be caused by incorrect hall angle configuration (60 degree or 120 degree)</p>
4, 3	aaaa aaa	Motor over-temperature	Motor temperature has exceeded the configured maximum. The controller will shut down until the motor temperature cools down.
Customers may read error codes in PC software or Android Tablet			

## Contact Us:

**Kelly Controls**

**Home Page:**

<http://www.KellyController.com>

**Download user manual,instructions and user program:**

[www.kellycontroller.com/support.php](http://www.kellycontroller.com/support.php)

**E-mail:**

[Sales@Kelly-Controls.com](mailto:Sales@Kelly-Controls.com)

**Phone:**

(01) 224 637 5092